

April 30, 1929.

H. C. IVES

1,710,702

MOTOR UNIT FOR TOY LOCOMOTIVES

Original Filed June 20, 1927

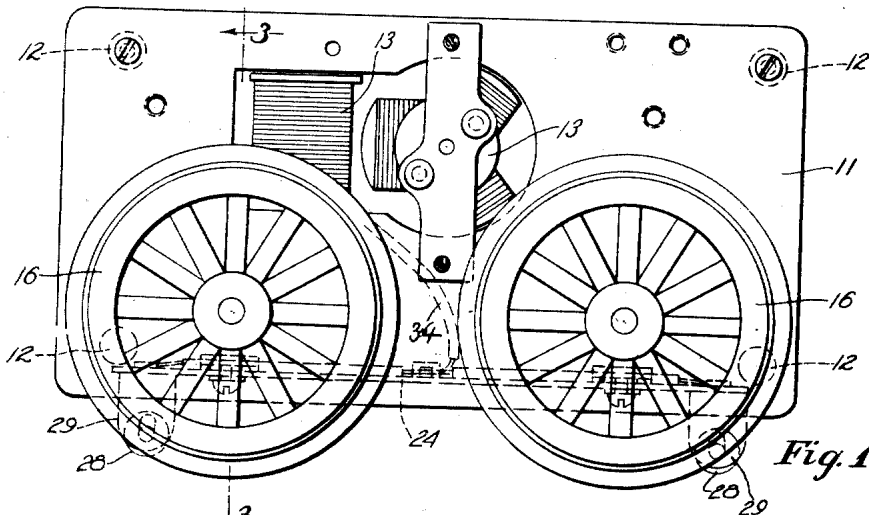

Fig. 1

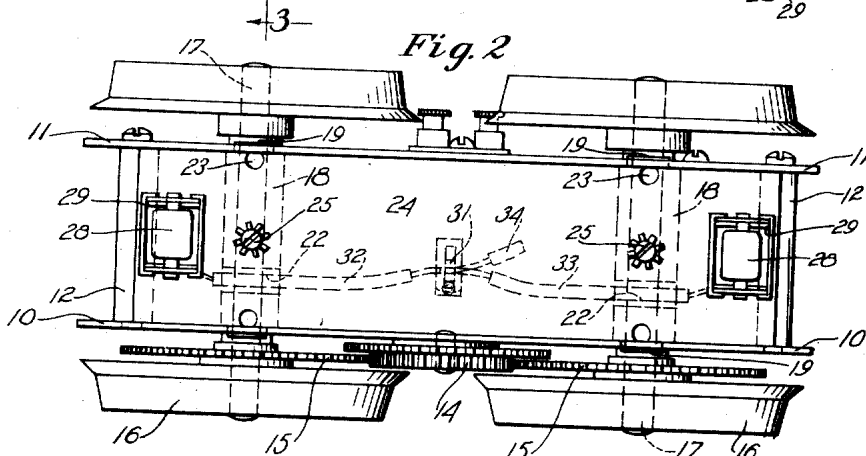

Fig. 2

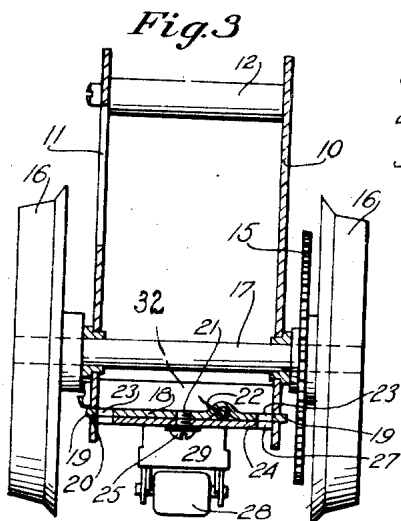

Fig. 3

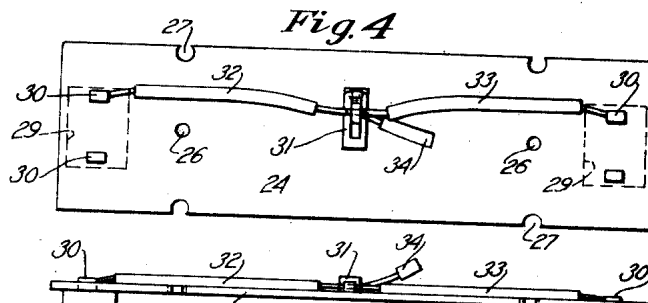

Fig. 4

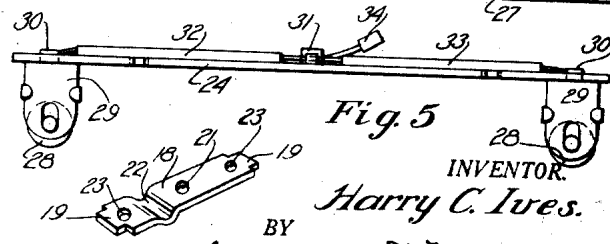

Fig. 5

INVENTOR.  
*Harry C. Ives.*  
BY  
*Chambulani & Newman*  
ATTORNEYS.

Patented Apr. 30, 1929.

# UNITED STATES PATENT OFFICE.

HARRY C. IVES, OF BRIDGEPORT, CONNECTICUT, ASSIGNOR, BY MESNE ASSIGNMENTS,  
TO THE IVES CORPORATION, OF BRIDGEPORT, CONNECTICUT, A CORPORATION  
OF CONNECTICUT.

## MOTOR UNIT FOR TOY LOCOMOTIVES.

Application filed June 20, 1927, Serial No. 199,926. Renewed October 27, 1928.

The present invention relates to improvements in motor units for toy locomotives, and has for an object to provide a structure of this kind of simple and inexpensive construction, which may be quickly assembled without the use of solder and taken apart for repairs and the like without the necessity of disassembling the frame structure. Heretofore it has been necessary, in order to obtain access to the motor, to separate the side frame plates so that it has been impracticable for the owners of the locomotives to repair them, and it has been the custom to return the motor to the factory for repairs. This has been particularly true with electric toy locomotives, and very often the trouble is merely a disconnected wire, which if the owner had ready access to the interior of the motor unit, could be repaired by him.

It is proposed in the present invention, therefore, to provide a motor frame structure including preferably of insulating material, a panel, secured in such manner to the lower portion of the frame that it may be readily removed without disturbing the frame structure, and when used in connection with an electric locomotive, it is proposed to provide means for easily assembling wires and proper fastenings for connections on such panel which may then be secured in place. I am aware that panels have previously been used and that wires have been carried thereby, but these panels were secured by means of laterally extending lugs provided upon them and engaged in slots in the side pieces of the frame, so that in order to remove the panel it was necessary to separate the side pieces. The present embodiment consists particularly in providing fixed supporting struts between the side plates, and to which the panel is secured by screws or the like, so that it may be readily removed by merely disengaging the screws.

With the above and other objects in view, an embodiment of the invention is shown in the accompanying drawings, and this embodiment will hereinafter be more fully described with reference thereto, and the invention will be finally pointed out in the claims.

In the drawings:—

Fig. 1 is a side elevation of an electric toy locomotive motor unit.

Fig. 2 is a bottom plan view thereof.

Fig. 3 is a vertical sectional view taken along the line 3, 3 of Fig. 1.

Fig. 4 is a top plan view of the separated panel.

Fig. 5 is a side elevation thereof.

Fig. 6 is a perspective view of one of the strut members employed, and to which the panel is adapted to be removably secured.

Similar reference characters indicate corresponding parts throughout the several figures of the drawings.

Referring to the drawings, the toy locomotive motor frame comprises side plates 10 and 11 secured in spaced relation by transverse posts 12, preferably at the four corners and between these plates the electric motor 13 is mounted, and is provided with suitable gearing 14 which meshes with gears 15 provided upon the wheels 16, the latter being mounted upon axles 17 journaled in the side plates. This type of motor is adapted to receive its current from the rails, being grounded upon one rail and having contact means adapted to engage another rail, said contact means being carried upon the removable panel, constituting the main feature of the present invention.

The frame is provided directly beneath the axles 17 with strut or brace members 18 secured in place by means of lugs 19 provided upon each end and engaged in slots 20 provided in the side plates, these brace members being provided substantially centrally with the threaded hole 21, for attachment of the panel, as will presently more fully appear, and further provided with a groove 22 pressed therein and adapted to straddle and position one of the lead wires. Adjacent each end of the brace members there are provided holes 23 disposed in such relation to the bearings of the axles 17 that such bearings may be oiled through these holes.

The panel 24 formed of fibre or other suitable insulating material is of substantially rectangular shape and is adapted to be fitted between the side plates and to engage the under sides of the brace members 18, and to be secured thereto by means of screws 25 engaged through holes 26 in the panel and screwed into the threaded holes 21 in the brace members. Holes 27 are provided in the panel in registering relation with the oil holes 23 of the brace members, so that the wheel axles may be oiled with the panel in place. At each end of the panel and at its under side there are provided contact rollers 28 rotatably mounted in box-like bearing sup-

ports 29 secured to the panel by means of lugs 30 engaged through slots provided in the panel and bent over from the upper side thereof. Substantially centrally of the upper side of the panel there is secured a spring terminal clip 31, the lugs 30 of the contact elements being electrically connected to this clip by means of lead wires 32 and 33, and the clip being connected to the motor by means of a flexible lead wire 34. The spring clip is of such construction that the lead wire 34 may be readily disconnected therefrom. In the attached position of the panel, lead wires 32, which are covered with suitable insulation and other wires if desired, may be retained in position by engaging within the grooves 22 provided in the transverse brace members 18, as clearly indicated in Figs. 2 and 3.

The panel, it will be noted, constitutes a closure for the motor frame completely protecting the interior thereof, but when it is desired for the purpose of repair or examination to obtain access to the interior of the frame, it is only necessary to remove the screws 25 and disconnect the lead wire 34 from the clip 31, whereupon the interior of the motor is completely exposed and repairs may be made therein, or upon the panel.

Obviously this may be conveniently done by anyone without requiring much skill or knowledge of mechanics, no soldering being needed, and repairs that would otherwise necessitate returning the motor to the factory can ordinarily be made by the owner of the toy locomotive. The brace members 18 constitute a permanent part of the frame and serve to provide additional reinforcement therefor, and while they provide sufficient support for the panel, they do not in any way interfere with the accessibility of the motor parts upon removal of the panel. In addition to the advantage of facilitating repairs to the motor, the present construction greatly simplifies and facilitates the manufacture and assembly of the motor unit. I have shown the motor unit as provided with an electric motor, in which case certain of the lead wires and the contact elements co-operating with the motor are carried upon the removable panel, but it is obvious that the invention also contemplates a motor frame provided with spring, momentum drive, or other types of motors.

I have illustrated and described a preferred and satisfactory embodiment of the invention, but it will be obvious that changes may be made therein, within the spirit and scope thereof, as defined in the appended claims.

Having thus described my invention, what I claim and desire to secure by Letters Patent is:

1. In a toy locomotive motor frame, a pair of side plates, means securing said side plates together in spaced relation, a motor carried

between said side plates, a closure panel, and securing means therefor adapted to secure the same transversely between said side plates and permitting removal of said panel without separation of said side plates.

2. In a toy locomotive motor frame, a pair of side plates, means securing said side plates together in spaced relation, a motor carried between said side plates, transverse strut means secured between said side plates, and a closure panel removably secured to said transverse strut means.

3. In a toy locomotive motor frame, a pair of side plates, means securing said side plates together in spaced relation, a motor carried between said side plates, said side plates being provided with aligned and spaced slots adjacent their lower edges, transverse strut means having end lugs engaged in said slots, and a closure panel removably secured to the under side of said strut means.

4. In a toy locomotive motor frame, a pair of side plates, means securing said side plates together in spaced relation, a motor carried transversely journaled in said side plates, wheels carried by said axles, transverse strut means secured between said side plates in spaced relation beneath said wheel axles, and a closure panel removably secured to the under side of said strut means.

5. In a toy locomotive motor frame, a pair of side plates, means securing said side plates together in spaced relation, a motor carried between said side plates, a pair of wheel axles transversely journaled in said side plates, wheels carried by said axles, transverse strut means secured between said side plates in spaced relation beneath said wheel axles, and a closure panel removably secured to the under side of said strut means, said strut means and said closure panel being provided with oil holes whereby said wheel axles may be oiled through said holes.

6. In a toy locomotive motor frame, a pair of side plates, means securing said side plates together in spaced relation, an electric motor carried between said side plates, a closure panel, and securing means therefor adapted to secure the same transversely between said side plates and permitting removal of said panel without separation of said side plates, and rail contact means carried by said closure panel.

7. In a toy locomotive motor frame, a pair of side plates, means securing said side plates together in spaced relation, an electric motor carried between said side plates, a closure panel, and securing means therefor adapted to secure the same transversely between said side plates and permitting removal of said panel without separation of said side plates, rail contact means carried by said closure panel at its under side, and lead wires carried by said closure panel at its upper side.

70

75

80

85

90

95

100

105

110

115

120

125

130

8. In a toy locomotive motor frame, a pair  
of side plates, means securing said side plates  
together in spaced relation, an electric motor  
carried between said side plates, a closure  
5 panel, and securing means therefor adapted  
to secure the same transversely between said  
side plates and permitting removal of said  
panel without separation of said side plates,  
rail contact means carried by said closure  
10 panel at its under side, lead wires carried  
by said closure panel at its upper side, a  
terminal clip carried by said closure panel  
at its upper side and engaged by said lead  
wires, and a lead wire connected to the motor  
15 and removably connected to said terminal  
clip.

9. In a toy locomotive motor frame, a pair  
of side plates, means securing said side plates  
together in spaced relation, an electric motor  
20 carried between said side plates, transverse  
strut means carried between said side plates

and having grooved portions transversely  
thereof, a closure panel removably secured to  
the under side of said strut means, rail con-  
25 tact means carried by said closure panel at  
its under side and outwardly of said strut  
means, and lead wires carried by said closure  
panel at its upper side, connected to said rail  
contact means and positioned and retained by  
said grooved portions of said strut means. 30

10. In a toy locomotive motor frame, a pair  
of side plates, means securing said side plates  
together in spaced relation, a motor carried  
between said side plates, a closure panel posi-  
35 tioned transversely between the lower part of  
said plates and adapted to be removed with-  
out separation of said plates.

Signed at Bridgeport, in the county of  
Fairfield and State of Connecticut, this 7th  
day of June, A. D. 1927.

HARRY C. IVES.