

No. 823,947.

PATENTED JUNE 19, 1906.

E. R. IVES.  
TOY RAILWAY AND TELEGRAPH POLE.  
APPLICATION FILED MAR. 12, 1906.

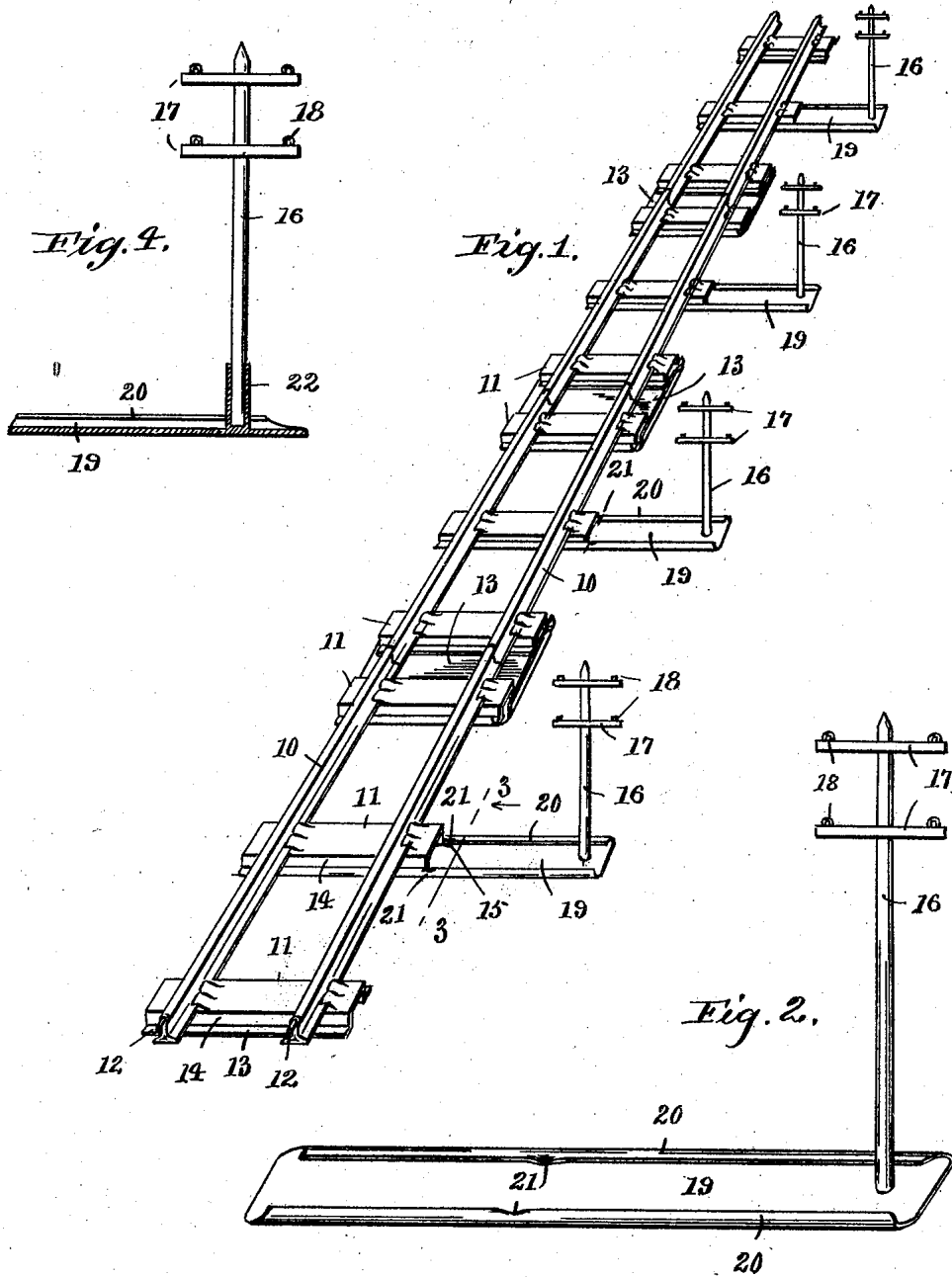

Witnesses  
Richard Brown  
S. B. Fallon.

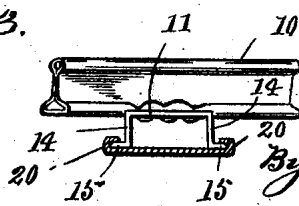

Inventor  
Edward R. Ives

By Chamberlain & Newman  
Attorneys

# UNITED STATES PATENT OFFICE.

EDWARD R. IVES, OF BRIDGEPORT, CONNECTICUT, ASSIGNOR TO THE  
IVES MANUFACTURING CORPORATION, OF BRIDGEPORT, CONNECTI-  
CUT, A CORPORATION OF CONNECTICUT.

## TOY RAILWAY AND TELEGRAPH-POLE.

No. 823,947.

Specification of Letters Patent.

Patented June 19, 1906.

Application filed March 12, 1906. Serial No. 305,456.

*To all whom it may concern:*

Be it known that I, EDWARD R. IVES, a citizen of the United States, and a resident of Bridgeport, in the county of Fairfield and State of Connecticut, have invented certain new and useful Improvements in Toy Railways and Telegraph-Poles, of which the following is a specification.

My invention relates to new and useful improvements in toy railway-tracks such as are referred to in my former patent of April 26, 1904, No. 758,448, and refers more especially to telegraph-pole connections for such tracks.

It is the object of my invention to provide a telegraph-pole of suitable design with means for its connections at proper intervals to toy tracks of the above general design, and especially for attachment to the "sleepers" or "ties," so called, of such tracks; to construct the device so that the pole may be readily set up and uniformly attached, preferably to the under side of such sleeper in a way to lend rigidity and strength to the road-bed; to design the pole so that when not in use it may be easily disconnected and packed away in a small space along with the several members of a sectional track of this kind.

Upon the accompanying sheet of drawings, forming a part of this specification, similar numerals of reference denote like or corresponding parts throughout the several figures, and of which—

Figure 1 shows a perspective view of a straight line of toy miniature railway-track such as are extensively manufactured and having a series of my improved telegraph-poles connected therewith. Fig. 2 shows a detached perspective view of one of my improved poles and attachable base-plates. Fig. 3 shows a detail cross-section through the base-plate, showing end of sleeper as taken on line 3 3 of Fig. 1. Fig. 4 shows a detail sectional elevation of a slightly-modified form of the invention, the same including a separable pole and base-plate.

The particular construction of track referred to will be well understood from Fig. 1 and is constructed of sheet metal bent up to form rails 10 and sleepers 11, which are of uniform designs and which are later assembled by the attachment of the rails to the sleepers as by means of swaging. The track is obviously formed in sections of suitable

lengths with preferably three sleepers to each section. These sections are made up in both straight and curved forms and are provided with means for securing the connecting ends together—as, for instance, pins 12 and plates 13, each of which has been already secured by me by prior patents. The sleepers referred to are of an inverted-trough-like design, having the lower edges of their sides 14 deflected outward in opposite directions to form flanged bearings 15, which also serve to be engaged by the turned-over edges of the plate 13, which holds the ends of the sections together, as well as serving to support the pole-base.

In the construction of a line I prefer to assemble in the order of one pole to each section, and elect to attach such pole to the intermediate or middle sleepers of each section.

In detail my invention comprises a pole 16, which may be formed of round wire or tubing and provided with cross-arms 17, having eyes 18 to receive light wires strung therethrough in imitation of large telegraph-wires. The lower end of the pole is preferably fixed to the outer end of an elongated base-plate 19, which in turn has its opposite parallel side edges turned over to form ways 20, which are designed to engage the side flanges 15 of the sleeper. The said inwardly-deflected edges of the base are further provided with indentations 21, as is clearly shown in Fig. 2, which serve as stops to engage the end of the sleeper and insure the proper uniform alignment of the series of poles with the track. This form of base for the poles permits of its convenient attachment to the track and raises the intermediate sleeper slightly to better conform to the position of the end sleepers, which are similarly raised by the introduction thereunder of the binding-plate 13, thus forming a more rigid support for the tracks. These poles may be attached to the track either before or after the sections of track are assembled.

In Fig. 4 I have shown a socket 22, attached to the base-plate, which extends up slightly in a way to receive the lower end of the pole and support the same in a vertical position, which obviously permits the pole and base to be disconnected and serves the purpose fully as well as the construction shown in Fig. 2 and likewise comes within the scope of my invention.

Having thus described my invention, what I claim, and desire to secure by Letters Patent, is—

1. The combination with a toy railway-track, of a base-plate for attachment to the track, and a pole secured to the top side of the outer end of the plate with means for the attachment of wires.
2. The combination with a toy railway-track, of a base-plate with means to engage a sleeper of the track and extend outward therefrom, and a pole mounted upon the outer end of the plate and bearing cross-arms for the attachment of wires.
3. The combination with a toy railway-track, having flanged sleepers, of an elongated attachable base-plate having ways to engage such flanges and adapted to extend out beyond the end of sleeper, and a pole secured to the top side of such outer end of the plate for the attachment of wires.
4. The combination with a toy railway-track including rails and sleepers, of a base-plate having ways to engage a sleeper and

containing a socket upon its outer end, a pole seated in the socket and extended upward from the plate and bearing cross-arms for the attaching of wires.

5. The combination with a miniature railway-track including rails and sleepers, of a base-plate with means for attachment to the track and constructed to extend outward therefrom, and a pole detachably connected to the top side of the base-plate.

6. The combination with a miniature railway-track including rails and sleepers, of a base-plate having ways to engage the edges of a sleeper, stops intermediate the ways to determine the position of the plates with relation to the sleeper and a pole bearing arms attached to said plate.

Signed at Bridgeport, in the county of Fairfield and State of Connecticut, this 8th day of March, A. D. 1906.

EDWARD R. IVES.

Witnesses:

JAMES M. SAXTON,  
M. S. PLATT.