

April 18, 1939.

J. L. BONANNO

2,155,343

REMOTE CONTROL SYSTEM, METHOD, AND APPARATUS

Filed Aug. 31, 1935

2 Sheets-Sheet 1

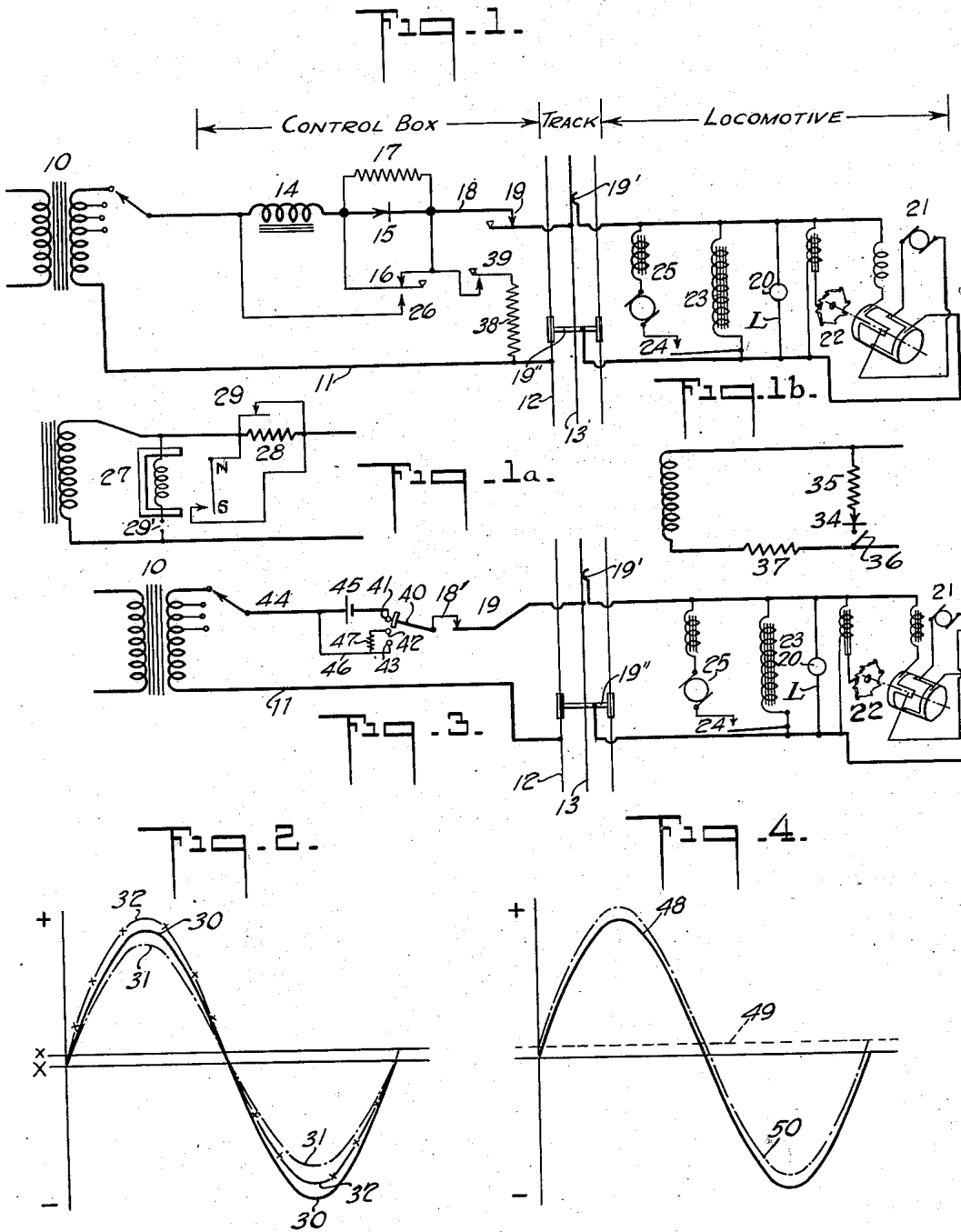

INVENTOR
JOSEPH L. BONANNO.

BY
Joel B. Liberman
ATTORNEY

April 18, 1939.

J. L. BONANNO

2,155,343

REMOTE CONTROL SYSTEM, METHOD, AND APPARATUS

Filed Aug. 31, 1935

2 Sheets-Sheet 2

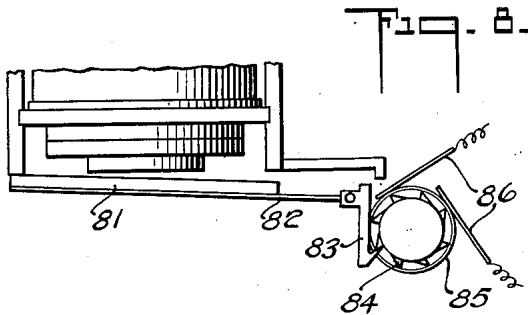
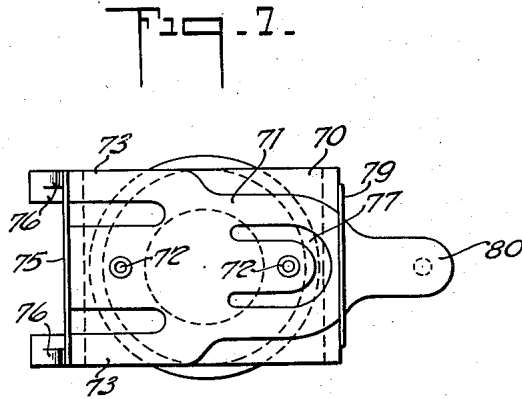
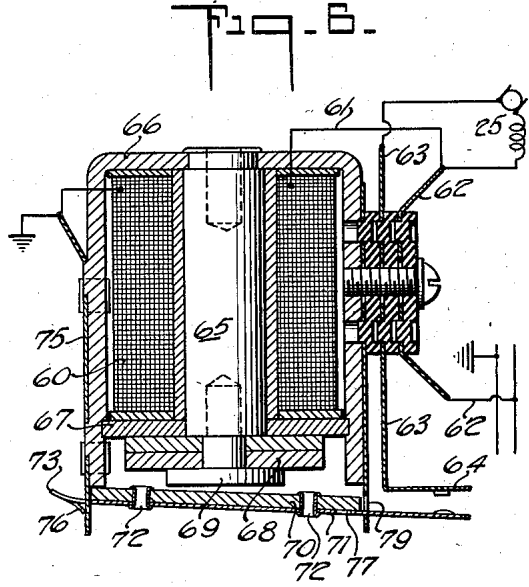
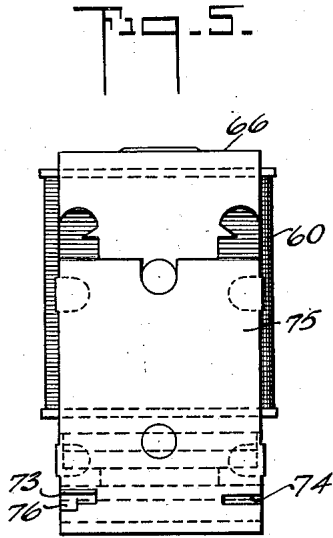

INVENTOR
JOSEPH L. BONANNO.
BY
Joel B. Liberman
ATTORNEY

UNITED STATES PATENT OFFICE

2,155,343

REMOTE CONTROL SYSTEM, METHOD, AND APPARATUS

Joseph L. Bonanno, Forest Hills, N. Y., assignor
to The Lionel Corporation, New York, N. Y.,
a corporation of New York

Application August 31, 1935, Serial No. 38,734

18 Claims. (Cl. 104—149)

The present invention relates to remote control systems, methods and apparatus.

In certain fields, such for example as the toy train art, it is desirable to provide the train with a remote controlled accessory such as a whistle, lights or bell in addition to the propulsion motor.

The present invention is particularly designed to provide for the operation of a whistle or other accessory on toy trains, this operation being entirely independent of the operation of the propulsion motor. The remote control circuit is, however, suitable for general application where conditions arise which are analogous to those involved in toy train operation.

The present invention contemplates a circuit having a source of alternating current potential such as a transformer of predetermined maximum voltage for operating a load such for example as lamps or propulsion motor. In addition to the accessory, which is normally connected to one side only of the current source, the circuit has a relay permanently connected in shunt with the load, this relay having contacts in the accessory circuit and being of the high reactance type designed so as not to close this circuit on the maximum alternating current potential which can be applied to it from the transformer. According to the present invention, this relay is adapted to function when a source of direct current of a small potential is introduced in series with the circuit. The direct current flows through the transformer and relay coils and effects a closing of the relay circuit when the direct current potential is applied and its opening when the direct current potential is removed, and this is utilized to control the circuit of the auxiliary device or signal such as a blower motor or a whistle, the actuating mechanism of a bell or any other current-consuming device adapted to operate on alternating current of the potential available.

The source of direct current for operating the relay may be a uni-directional conductor, such as a rectifier in series with the load circuit and normally shunted so as not to function, or in parallel with the load circuit and normally open-circuited so as not to function. When the rectifier is in circuit, it generates a sufficient amount of direct current to flow through the transformer coil and the relay coil to operate the relay. In the case of a series rectifier (preferably shunted), there is some resistance drop in the rectifier and shunt, and, as added current is necessary for operating the relay controlled accessory, there

would ordinarily be a drop in potential of the current supplied to the load causing the lamps to dim and the propulsion motor to slow down. To overcome this, the circuit is preferably provided with a choke coil which may be short-circuited when the rectifier is unshunted. A single switch may effect both operations. A small rectifier may be used, as the accessory is operated for short intervals only.

Instead of employing the rectifier to obtain a low direct current potential, it is also possible to introduce a battery such as an ordinary dry cell into the circuit, the battery then being in series with the transformer and relay coils so that the relay will be operated. The amount of energy drawn from the battery during the short intervals of time the device is operated is small, and the life of the battery is satisfactory.

Other and further objects of the invention will appear as the description proceeds.

The accompanying drawings show, for purposes of illustrating the present invention, several embodiments in which the invention may take form, it being understood that the drawings are illustrative of the invention rather than limiting the same.

In these drawings,

Fig. 1, 1a and 1b are circuit diagrams showing a remote control system utilizing rectifiers;

Fig. 2 is a wave form diagram illustrating the wave form of the currents employed;

Fig. 3 is a circuit diagram illustrating the utilization of a battery for obtaining the superposed direct current;

Fig. 4 is a diagram illustrating the superposing of the direct current on the alternating current wave;

Fig. 5 is a side elevational view of a relay;

Fig. 6 is a sectional view through the relay;

Fig. 7 is an inverted plan view of the same; and

Fig. 8 illustrates an indexing type of relay.

In the arrangement shown in Fig. 1, the alternating current source such as a transformer is indicated at 10. This transformer is indicated as having a variable voltage output, but for toy train operation is designed to give a maximum voltage of 25 volts. The transformer is connected by the wire 11 with one of the wheel-bearing rails 12 of a toy railroad track. The other side of the transformer is connected to the third rail 13 of the toy railroad track layout by an impedance 14, preferably an inductance or choke coil (on account of heating), a half-wave rectifier 15 (shunted by

a normally closed switch 16 and by a resistance 17), wire 18 and manually operable train-controlling switch 19.

As the half-wave rectifier blocks out one half of an alternating current wave, the power transmission would be halved if a resistor such as 17 were not provided. This resistor carries a substantial portion of the power supply and insures more uniform operation of the load.

The structures diagrammatically illustrated at the right of the railroad track are those carried on the locomotive or train. The current is picked up by the usual current collector 19' bearing on the third rail and returned through the axles 19''. A load, indicated at L, may include lamps on the cars or locomotive indicated at 20, and a propulsion motor 21 whose field and armature are interconnected with the supply line by a reversing switch 22. This reversing switch is electromagnetically operated and is preferably of the type which operates to stop the propulsion motor or reverse its direction of rotation when the manual train controlling switch 19 is manipulated. This type of reversing switch does not affect the train lights. It is in common use in this art.

The train also carries a relay 23 which is permanently connected to the terminals of the toy locomotive or car. This relay is shown more in detail in Figs. 5 to 8. It is constructed so that the maximum alternating current voltage available will not operate the relay so as to close the circuit indicated at 24, or operate an indexing mechanism. The contact 24 is in series with the accessory 25 to be operated when the relay functions. This is here indicated in the form of a motor having the usual field and armature. This motor may be employed to operate a blower for producing an air whistle, or any other form of current consuming device may be employed.

When the circuit parts are in normal position indicated in Fig. 1 of the drawings, alternating current is flowing through the choke coil 14, the shunt 16, wire 18, switch 19, third rail 13, collector shoe 19', then through the load 20 and 21 and coil of the relay 23, wheels 19'', track rail and wire 11 to the other side of the transformer. If the switch 16 is pressed part-way down, the shunt about the rectifier 15 is opened and, owing to the drawing of current through the rectifier, it generates a direct current. This direct current potential is impressed upon the circuit, including the choke coil 14, transformer wire 11, track 12, relay coil and load, third rail 13, switch 19 and wire 18. This direct current potential may be as low as one-half a volt and yet satisfactorily operate the relay 23. As long as the switch 16 is held part-way down, and these conditions maintain, the relay 23 holds the contact 24 so that the blower or other accessory is operated. The switch 16 is preferably provided with an additional contact 26 so that when the switch 16 is pressed all the way down, the choke coil 14 is shunted so as to offset the resistance drop in the rectifier 15 and resistance 17 and restore substantially the normal voltage to the load circuit.

Instead of a half-wave dry type rectifier, one may, as shown in Fig. 1a, employ a vibratory rectifier 27 connected across a shunting resistance 28, control being effected by shunting the resistance by a switch 29 or stopping the vibrator by a switch 29'.

Another means of introducing the equivalent of a direct current component is shown in Fig. 1b. It employs a rectifier 34 and current limiting resistance 35 which may be connected across

the line by a switch 36. If necessary, a series impedance 37 may be inserted.

The approximate wave forms of the currents in the circuit of Fig. 1 are indicated in Fig. 2, phase shifting being ignored, and differences in absolute values slightly exaggerated. The alternating current sine wave 30 has an axis X. When the switch 16 is pressed part way down so as to un-shunt the rectifier, the wave form is that indicated at 31, producing distortion. The axis of this wave is displaced, as indicated at x. The average direct current component is indicated by this displacement. When the switch 16 is pressed all the way down so that the coil 14 is shunted, the amplitude of the wave form 31 is increased as indicated at 32 and restored to the original effective value.

When the train is standing still on the track, no current is drawn by the propulsion motor. The lamp load may be so small that insufficient direct current voltage is developed in the rectifier to operate the relay. In order to load the rectifier, the control box, which normally includes the structures between the transformer and the track, is provided with an auxiliary resistance 38 connected to a normally open switch 39. Closing switch 39 will load the rectifier and send the direct current through the relay so that the whistle or other accessory may be operated.

In the arrangement shown in Fig. 3, the rectifier and auxiliary circuits are replaced by a battery such as a dry cell for obtaining the direct current. Here the wire 18' corresponding to the wire 18 of Fig. 1 is connected to a switch arm 40 which is adapted to pass over three contacts 41, 42 and 43. The switch arm is broad enough to bridge two adjacent contacts. Contact 41 is connected to the transformer lead 44 by a battery such as a dry cell 45. The lead 44 is connected directly to the contact 43 by a wire indicated at 46, and is connected to the contact 42 through a small resistor 47.

When the switch arm 40 is in contact with 43, alternating current is supplied to the load circuit and when it is shifted so that it engages only the contact 41, alternating current on which is superposed a small direct voltage is supplied to the load circuit. The impedance offered by the battery to the alternating current is very small so that the battery is not overheated thereby. In intermediate position, the battery 45 is short-circuited through the resistance 47 so that the circuit is not opened. The relay operates the same as above described.

In Fig. 4 the sinusoidal alternating current wave is indicated at 48, and the direct current potential at 49. The resulting wave form is indicated at 50.

In both the circuit arrangements above indicated, it will be noted that the operation of the whistle or other accessory is achieved without opening the load circuit. This is particularly important in toy trains having automatic reversing mechanism, as any opening of the circuit, even momentarily, will operate the reversing mechanism.

The relay 23, 24 is indicated in detail in Figs. 5, 6 and 7. It is provided with a coil 60 having one end connected by a wire 61 with an insulated terminal plate 62 and the other end grounded. This terminal plate is adapted to be connected by a wire 62' with the collector shoe bearing on the third rail. The terminal plate 62 is also connected through the field and armature of the motor or other accessory 25. The opposite side

of this accessory is connected to an insulated relay contact 63 whose lower end is bent outwardly as indicated at 64.

The coil 60 is placed about a core 65 and the core is mounted in between a U-shaped body or yoke 66 and magnetic shunt 67 having low residual magnetism. The core 65 carries copper lag rings 68 and a core-head 69. The armature is indicated at 70. It is secured to an armature spring 71 by rivets indicated at 72. The armature spring has the configuration shown in Fig. 7. It has two hinge-forming extensions 73, 73 adapted to pass through openings 74 in the hinge plate 75 and downwardly struck prongs 76 to prevent removal of the armature. These spring extensions are tensioned to exert a lifting action on the adjacent end of the armature and hold it against the yoke 66. The armature spring has a U-shaped slot indicated at 77 and extends through a slot in the plate 79. It has a contact 80 opposite the extension 64 on the contact member 63 so as to ground the accessory 25.

For the purposes above described, the relay is designed so as not to close on any alternating current voltage obtainable from the transformer. Where the maximum normal voltage is 25 volts, the closing voltage for the relay is kept above 28 to 30 volts.

It will be noted that the relay has a path of low reluctance for the alternating current flux, and that the leakage flux through the air gap to the armature is kept to a minimum by the design of the core head and the copper lag rings. In the design, the portion of the core passing through the lag rings is made of very small cross-section so as to increase the efficiency of the lag rings and produce a large drop in magnetomotive force through the air gap. On direct current the lag rings become ineffective and there is sufficient leakage flux in the air path (owing to the proportioning of the main core and shunt paths) to attract the armature mechanically and to hold the armature in the raised position.

Owing to the manner in which the armature is mounted at the pivot point, considerable lifting force is exerted at the hinge point by the springs 73 so as to obtain a good electrical and magnetic contact between the armature and adjacent end of the yoke. This good magnetic contact is available without in any way affecting the pull required to raise the armature, except for the slight amount of friction introduced at the hinge.

In the arrangement shown in Fig. 8, the relay armature 81 is provided with an extension 82 carrying a ratchet pawl 83 cooperable with a ratchet wheel 84 on a drum 85. This drum may carry contacts for controlling auxiliary circuits in accordance with the position to which it is moved by the relay. With this type of relay, an operation is effected each time a direct current impulse is impressed on the line.

The electromagnetic device shown in Figures 5 to 8, inclusive, forms the subject matter of my divisional application, Serial No. 263,386 filed Mar. 22, 1939.

It is obvious that the invention may be embodied in many forms and constructions within the scope of the claims, and I wish it to be understood that the particular forms shown are but a few of the many forms. Various modifications and changes being possible, I do not otherwise limit myself in any way with respect thereto.

What is claimed is:

1. A remote control system having a load,

an alternating current source of predetermined maximum potential and uniform frequency for operating said load, a relay in shunt with the load, the relay being incapable of operating on said alternating current potential and frequency but operable on a small direct current potential, a resistance shunted rectifier in series with the relay, source, and load, a normally closed shunt about the rectifier whereby a small direct current potential may be introduced into the circuit when the normally closed shunt is opened, the resistance shunted rectifier then having insufficient reactance to interfere with operation of the load, and a translating device whose circuit is controlled by the relay when operated by said direct current source.

2. A remote control system as claimed in claim 1, having an impedance normally in series with the source, and a switch for short circuiting the impedance when the rectifier shunt is opened.

3. A remote control system as claimed in claim 1, having an impedance normally in series with the source, and a switch for short circuiting the impedance when the rectifier shunt is opened, the voltage drop in the impedance being substantially equal to the voltage drop in the rectifier so that the voltage supplied to the load is substantially the same when the rectifier is short circuited and the impedance not shunted as it is when the rectifier is not short circuited and the impedance is short circuited.

4. A remote control system as claimed in claim 1, having an artificial load for the rectifier whereby direct current may be had for operating the relay when the first mentioned load draws insufficient current.

5. A remote control system having a load, an alternating current source of predetermined maximum potential and uniform frequency for operating said load, a relay in shunt with the load, the relay being incapable of operating on said alternating current potential and frequency but operable on a small direct current potential, a half wave rectifier provided with a resistance shunt and a normally closed shunt whereby a small direct current potential sufficient for actuating the relay may be introduced into the circuit upon the opening of the normally closed shunt and while the alternating current is supplied to the load.

6. In combination, a track having two rails insulated from one another, a vehicle having current collectors, a vehicle carried propulsion motor and relay both connected to the track for energization when the track is energized, a vehicle carried accessory having one side of its circuit connected to one rail and the other side connected to the other rail only when the relay is energized, a source of alternating current connected to the track for operating the motor, the alternating source being of uniform frequency and incapable of operating the relay to close the accessory circuit, and means to introduce a small direct current potential into the track supply circuit without opening said track supply circuit or interfering with the flow of power to the propulsion motor whereby the relay may be operated to connect the accessory to the alternating current source for operation thereby.

7. The combination set forth in claim 6, wherein the direct current potential is derived from a rectifier connected between the alternating current source and one rail so as to be in series with the motor.

8. The combination set forth in claim 6, where-

in the direct current potential is derived from a rectifier connected between the alternating current source and one track so as to be in series with the motor, and having in series therewith an impedance adapted to be shunted when the rectifier is operated.

9. The combination set forth in claim 6, wherein the direct current potential is derived from a rectifier connected between the alternating current source and one track so as to be in series with the motor, and having a supplemental load adapted to be connected to the rectifier when the propulsion motor is disconnected.

10. The combination set forth in claim 6, wherein the direct current potential is derived from a battery normally out of circuit but connected between the source and one rail through a switch.

11. In combination, a load, an alternating current source of predetermined maximum potential and uniform frequency for supplying power to said load, a relay comprising a coil connected to said source and in parallel with the load, a magnetic structure of low reluctance for alternating current flux, an armature unaffected by said alternating current flux whereby the coil may be continuously in circuit with said source, and circuit controlling means actuated by the armature, an accessory in shunt with the coil and in circuit with said circuit controlling means and the alternating current source, and a source of low voltage direct current which may be introduced at will in series with the load and the coil without opening the load circuit or interfering with the flow of power to said load, the direct current source producing a direct current flux which attracts the armature and operates said means whereby the accessory is energized from said source.

12. A remote control system having a load, an alternating current source of predetermined maximum potential and uniform frequency for operating said load, a relay in shunt with the load, the relay being incapable of operating on said alternating current potential and frequency but operable on a small direct current potential whereby the relay may be continuously in circuit with said source, means adapted to be connected in series with the alternating current load and independent of the source for altering the wave form of the currents flowing through the relay and load without opening the circuit to said load or interfering with the flow of power to said load and whereby the equivalent of an unidirectional current is supplied to the relay windings effective to operate the relay while still subject to the alternating current, and a current consuming device operable by current from the alternating current source and whose circuit is controlled by the relay when operated by said unidirectional current.

13. A remote control system in accordance with claim 12, wherein the means for altering the wave form is a rectifier.

14. A remote control system in accordance with claim 12, wherein the means for altering the wave form is a battery.

15. In combination, a load, an alternating current source of predetermined maximum potential and uniform frequency for supplying power to said load, a relay comprising a coil connected to said source and in parallel with the load, a magnetic structure of low reluctance for alternating current flux, an armature unaffected by said al-

ternating current flux whereby the coil may be continuously in circuit with said source, and circuit controlling means actuated by the armature, an accessory in shunt with the coil and in circuit with said circuit controlling means and the alternating current source, and a rectifier which may be introduced at will in series with the load and the coil without opening the load circuit or interfering with the flow of power to said load, the direct current source producing a direct current flux which attracts the armature and operates said means whereby the accessory is energized from said source.

16. In combination, a load, an alternating current source of predetermined maximum potential and uniform frequency for supplying power to said load, a relay comprising a coil connected to said source and in parallel with the load, a magnetic structure of low reluctance for alternating current flux, an armature unaffected by said alternating current flux, whereby the coil may be continuously in circuit with said source, and circuit controlling means actuated by the armature, an accessory in shunt with the coil and in circuit with said circuit controlling means and the alternating current source, and a battery which may be introduced at will in series with the load and the coil without opening the load circuit or interfering with the flow of power to said load, the direct current source producing a direct current flux which attracts the armature and operates said means whereby the accessory is energized from said source.

17. In combination, a load, an alternating current source of predetermined maximum potential and uniform frequency for supplying power to said load, a relay comprising a coil connected to said source and in parallel with the load, a magnetic structure of low reluctance for alternating current flux, an armature unaffected by said alternating current flux whereby the coil may be continuously in circuit with said source, and normally open relay contacts actuated by the armature, an accessory in shunt with the coil and in circuit with said contacts, and the alternating current source, and a source of low voltage direct current which may be introduced at will in series with the load and the coil without opening the load circuit or interfering with the flow of power to said load, the direct current source producing a direct current flux which attracts the armature and closes the relay contacts to energize the accessory from said source.

18. In combination, a load, an alternating current source of predetermined maximum potential and uniform frequency for supplying power to said load, a relay comprising a coil connected to said source and in parallel with the load, a magnetic structure of low reluctance for alternating current flux, an armature unaffected by said alternating current flux whereby the coil may be continuously in circuit with the said source, indexing mechanism actuated by the armature, and a circuit controller in series with the alternating current source and operated by the indexing mechanism, and a source of low voltage direct current which may be introduced at will in series with the load and the coil without opening the load circuit or interfering with the flow of power to said load, the direct current source producing a direct current flux which attracts the armature and operates the indexing mechanism.