

(No Model.)

2 Sheets—Sheet 1.

J. SCHOENNER.
TOY GAS MOTOR.

No. 548,012.

Patented Oct. 15, 1895.

Fig. 1

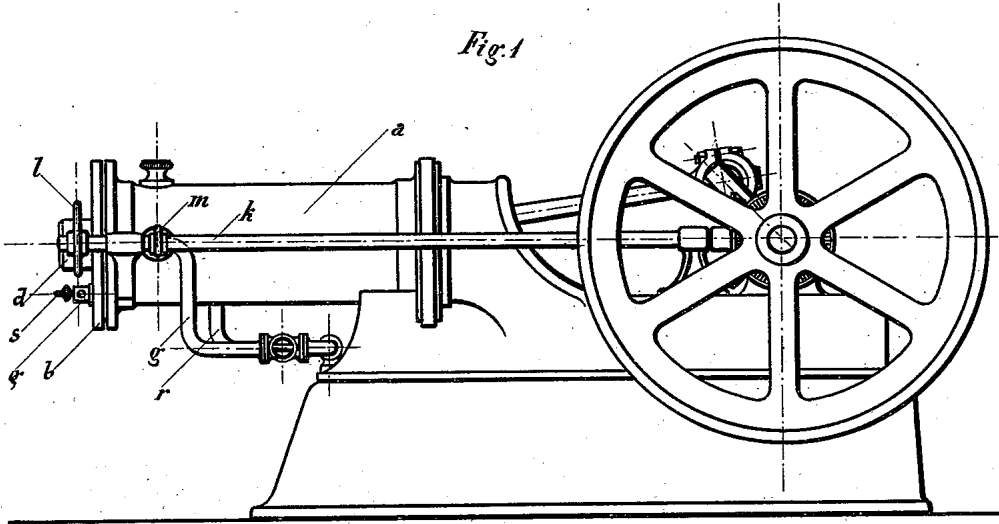
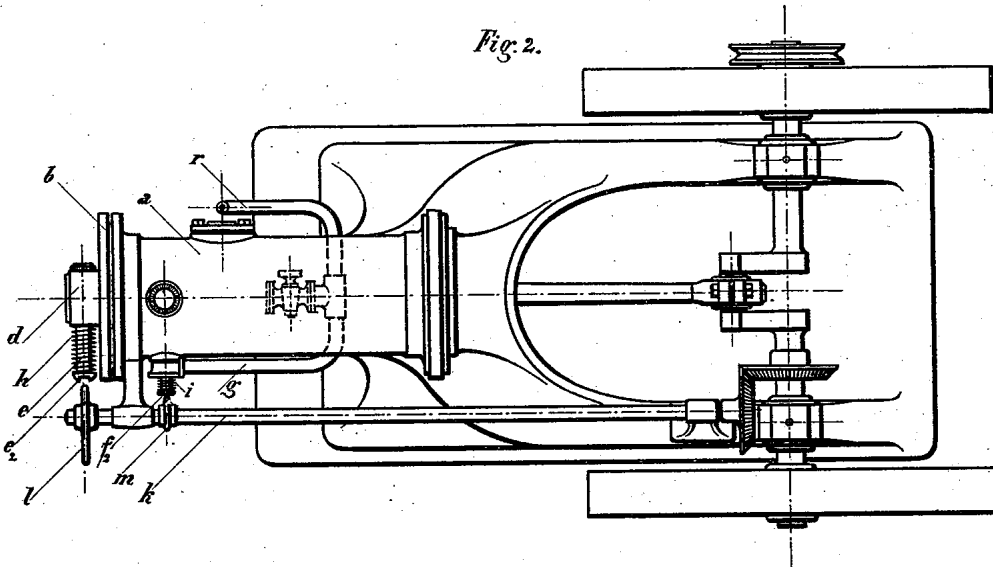

Fig. 2.



Witnesses

H. B. Hammond.

J. B. Raige

Inventor

Jean Schoenner

By *Clara A. Raige*

Att'y -

UNITED STATES PATENT OFFICE.

JEAN SCHOENNER, OF NUREMBERG, GERMANY.

TOY GAS-MOTOR.

SPECIFICATION forming part of Letters Patent No. 548,012, dated October 15, 1895.

Application filed July 24, 1894. Serial No. 518,415. (No model.) Patented in Germany March 29, 1894, No. 77,060, and September 30, 1894, No. 80,120; in England May 30, 1894, No. 10,511; in France October 10, 1894, No. 241,975, and in Austria November 21, 1894, No. 44/6,022.

To all whom it may concern:

Be it known that I, JEAN SCHOENNER, manufacturer, a subject of the German Emperor, residing at Nuremberg, in the Kingdom of Bavaria, Empire of Germany, have invented certain new and useful Improvements in Toy Gas-Motors, (for which Letters Patent have been granted in foreign countries as follows: in Germany, No. 77,060, dated March 29, 1894, and No. 80,120, dated September 30, 1894; in France, No. 241,975, dated October 10, 1894; in Great Britain, No. 10,511, dated May 30, 1894, and in Austria, No. 44/6,022, dated November 21, 1894,) of which the following is specification.

Among the toy models serving more particularly for instruction small motors suitable for producing a small amount of power take in recent times one of the foremost positions, corresponding to the progressive development and extension of technology. This industry has hitherto been limited merely to the manufacture of steam-motors. Toy gas-motors have, on the other hand, not hitherto been in general use, although such, in consequence of the possibility of obtaining a somewhat large amount of power and the wide distribution of gas-motors in all branches of manufacturing industry, may be considered as peculiarly suitable for toy models. The reason for this must be found in the difficulties which are encountered in producing a reliable working gas-motor of the necessary small dimensions, regard being had simultaneously to the simplicity and cheapness requisite for this special purpose.

This invention has for its object the production of a toy gas-motor, which by reason of its peculiar mode of action, construction, and arrangement of the main parts, is very suitable for making on a small scale, and, further, places clearly before the eyes of the persons playing with it (which is of great importance) the principle of the operations in the cylinders of gas-motors.

This improved toy gas-motor is made on the principle in which the mixture of gas and air present in the cylinder is not first compressed before being exploded. It works in the following manner: On the moving forward

of the piston out of its rear end position first air and then gas is drawn in. Thereupon the mixture formed is ignited immediately behind the piston, and the latter is driven forward to the end of its stroke by the resultant expansion. On the return of the piston the gaseous products of combustion are forced out through the air-inlet opening.

The arrangement of motor acting in the above-named manner is shown on the accompanying drawings in Figures 1 to 8.

Fig. 1 is a side elevation of the gas-motor; Fig. 2, a plan view; Figs. 3, 5, and 7, sectional views of the piston in different positions. Figs. 4, 6, and 8 are details.

At the deepest point of the cylinder *a*—namely, in the cover *b*—is formed the air-inlet opening *c'*, forming the mouth of a passage *c*, bored through the projection *d*. This passage is interrupted by a piston-slide *e*, which is moved vertically to the axis *x* of the cylinder, and, according to the position which it assumes, closes the opening *c* to the outer air, or by means of its perforation *e'* connects the same with the outer air. Somewhat farther along there is placed on the circumference of the cylinder a gas-admission valve *f*, which is connected by means of the branch *f'* and the pipe *g* to the gas-main. Both valves are automatically closed by means of springs *h* and *i* and operated by means of the spindle *k* at the side of the cylinder. On this spindle there are for this purpose two eccentric disks or projections *l* and *m*, which on the rotation of the spindle *k* act on the front ends *e²* and *f²* of the valves *e* and *f* and press down the same, overcoming the resistance of the springs *h* and *i*. The disks *l* and *m* are so formed that the opening of the air or of the gas inlet always takes place at the right moment.

The ignition in this improved toy or model motor is brought about by means of an open lighting-flame, which burns from a tube *r*, placed outside the cylinder and opening beneath the ignition-opening *o*. This last-named opening *o* is covered by a valve *p* which opens inward. The valve *p* may, however, be omitted and the ignition may take place directly by means of the opening *o*, which is a very small one. The gas-motor

arranged in this manner works as follows: In the deepest position of the piston, as shown in Figs. 3 and 4, the air-admission passage *c* is opened, and the piston therefore first draws
 5 in air on moving forward. The disk *l* is so formed that after the requisite quantity of air has been drawn in the slide *e* is released and springs upward by means of the spring
 10 *h*, and thus closes the air-inlet. When this moment has been reached, the gas-valve *f* is opened by means of the disk *m* and the requisite quantity of gas is supplied to the cylinder, which mixes with the air already contained in the same. The ignition-opening *o*,
 15 which was hitherto covered by the piston *k*, is so arranged that the piston passes away and has its rear edge only over the same when the mixture of gas and air has been completed. The valve *p*, in case such is employed, opens,
 20 consequently, inward and the flame *r'*, following the draft of air, passes into the cylinder, where it ignites the explosive mixture. The piston *k* is driven forward into its front end position by means of the power of expansion
 25 thereby developed. When this position is attained, the air-inlet is opened by the disk *l*, and on the subsequent return of the piston the products of combustion are expelled through this opening. The ignition-valve is
 30 thus closed, and the gas-inlet valve also remains closed during the return movement. The same process is repeated on the piston again moving forward, and a regular movement of the motor is produced by the above-
 35 described simple means, as has been determined by thorough experiments.

In order to equalize small inequalities of the valves, unavoidable in toys, changes in the composition of the mixture of gas and air,
 40 and local circumstances, there is arranged in the cover of the cylinder a second air-valve

q, which opens on the piston moving forward and also allows air to flow in. The movement of this secondary air-valve may be regulated
 45 by means of a screw *s*, so that the quantity of air conveyed through the same may be increased or diminished, according to requirements. The valve *q*, here indicated, is an ordinary self-acting valve opening inward by
 50 pressure from outside and closing on pressure from inside, its degree of opening being limited by the screw *s*, as stated.

As the essential constituents, more particularly the valves, lie at the outside and their
 55 function may be followed with the eye, the mode of action of the motor is clearly visible from the outside, and the principle of the gas-motor may be more easily understood by means of this model in a comprehensible
 60 manner.

I declare that what I claim is—

In a gas motor, the combination of a piston, a cylinder having an air inlet serving also as a discharge at its head, a gas inlet beyond the
 65 head, and an ignition device, valves for the combination air inlet and discharge and for the gas inlet, and mechanism whereby the combination air inlet valve is first opened, then the
 70 gas inlet opened, then the air and gas inlets closed and the ignition device operated, and the combination air inlet and discharge then opened and held open to expel the products and again admit the air, substantially as described.

In testimony whereof I have signed my
 75 name to this specification in the presence of two subscribing witnesses.

JEAN SCHOENNER.

Witnesses:

WM. J. BLACK,
 OSCAR BOCK.